

# *Eclipse Winnox* *Burners*

*WX Series*  
*Version 1*

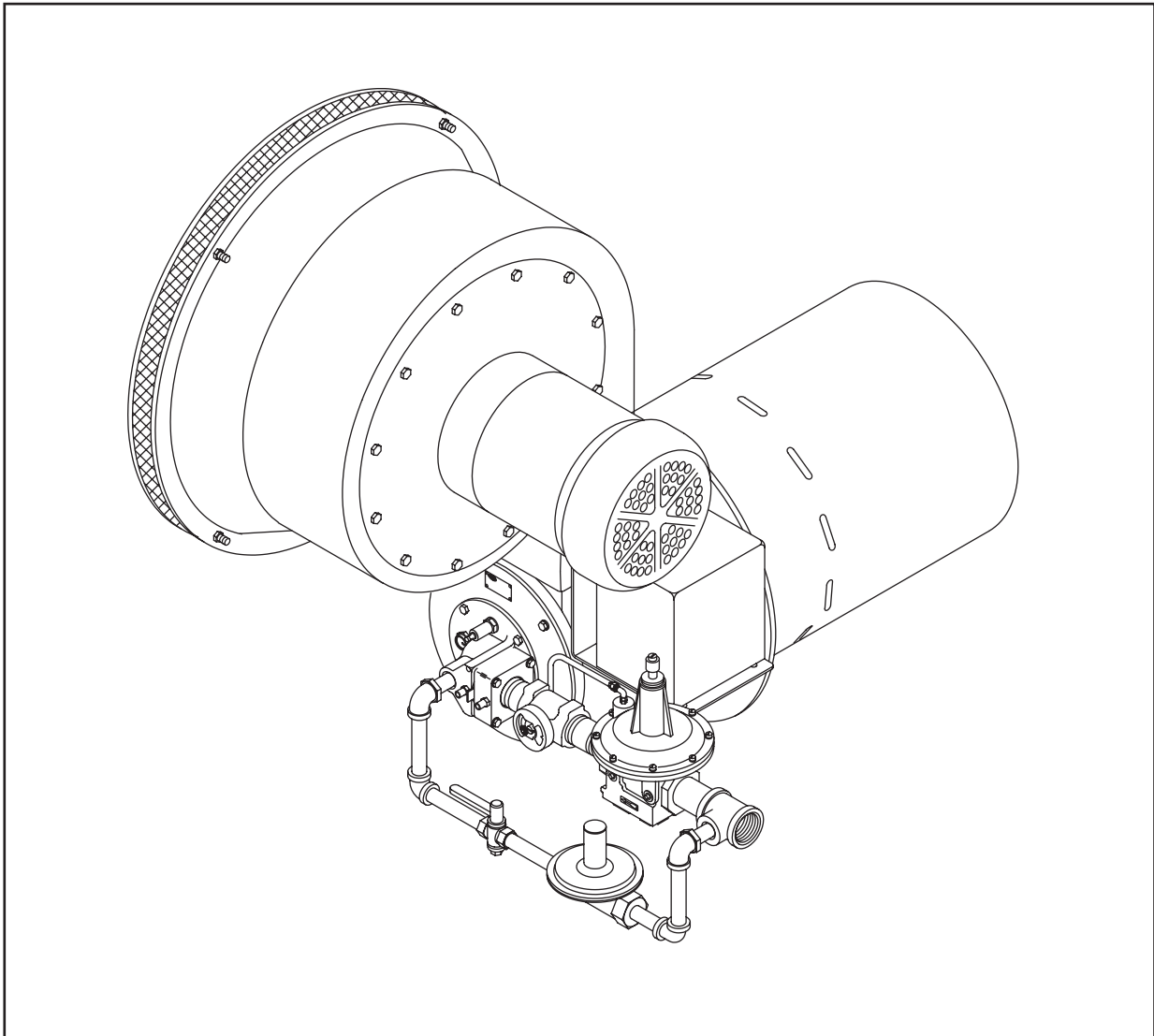

## **COPYRIGHT**

Copyright 2005 by Eclipse, Inc. All rights reserved worldwide. This publication is protected by federal regulation and shall not be copied, distributed, transmitted, transcribed or translated into any human or computer language, in any form or by any means, to any third parties, without the express written consent of Eclipse, Inc.

## **DISCLAIMER NOTICE**

We reserve the right to change the construction and/or configuration of our products at any time without being obliged to adjust earlier supplies accordingly.

The material in this manual is believed adequate for the intended use of the product. If the product is used for purposes other than those specified herein, confirmation of validity and suitability must be obtained. Eclipse warrants that the product itself does not infringe upon any United States patents. No further warranty is expressed or implied.

We have made every effort to make this manual as accurate and complete as possible. Should you find errors or omissions, please bring them to our attention so that we may correct them. In this way we hope to improve our product documentation for the benefit of our customers. Please send your corrections and comments to our Marketing Communications Manager.

## **LIABILITY AND WARRANTY**

It must be understood that Eclipse's liability for its product, whether due to breach of warranty, negligence, strict liability, or otherwise is limited to the furnishing of replacement parts and Eclipse will not be liable for any other injury, loss, damage or expenses, whether direct or consequential, including but not limited to loss of use, income, or damage to material arising in connection with the sale, installation, use of, inability to use, or the repair or replacement of Eclipse's products.

Any operation expressly prohibited in this Guide, any adjustment, or assembly procedures not recommended or authorized in these instructions shall void the warranty.



# *About This Manual*

## **AUDIENCE**

This manual has been written for people who are already familiar with all aspects of a nozzle-mix burner and its add-on components, also referred to as “the burner system”.

These aspects are:

- Design / Selection
- Use
- Maintenance

The audience is expected to have previous experience with this type of equipment.

## **WINNOX DOCUMENTS**

### **Design Guide No. 111**

- This document

### **Datasheet, Series 111**

- Available for individual WX models
- Required to complete design and selection

### **Installation Guide No. 111**

- Used with Datasheet to complete installation

### **Price List No. 111**

- Used to order burners

### **Related Documents**

- EFE 825 (Combustion Engineering Guide)
- Eclipse Bulletins and Info Guides: 684, 710, 732, 742, 756, 760, 930

### **Purpose**

The purpose of this manual is to ensure that the design of a safe, effective, and trouble-free combustion system is carried out.

## DOCUMENT CONVENTIONS

There are several special symbols in this document. You must know their meaning and importance.

The explanation of these symbols follows below. Please read it thoroughly.



**Danger:**

---

Indicates hazards or unsafe practices which **WILL** result in severe personal injury or even death.

Only qualified and well trained personnel are allowed to carry out these instructions or procedures.

Act with great care and follow the instructions.

---



**Warning:**

Indicates hazards or unsafe practices which could result in severe personal injury or damage.

Act with great care and follow the instructions.



**Caution:**

Indicates hazards or unsafe practices which could result in damage to the machine or minor personal injury, act carefully.



**Note:**

Indicates an important part of the text. Read thoroughly.

## HOW TO GET HELP

If you need help, contact your local Eclipse representative.



# *Table of Contents*

<b>1</b>	<b>Introduction</b> .....	6
	Product Description .....	6
<b>2</b>	<b>Safety</b> .....	7
	Introduction.....	7
	Safety .....	7
	Capabilities .....	7
	Operator Training.....	7
	Replacement Parts .....	7
<b>3</b>	<b>System Design</b> .....	8
	Design .....	8
	Step 1: Burner Option Selection.....	9
	Step 2: Packaged Blower Option Selection.....	11
	Step 3: Control Methodology .....	12
	Step 4: Ignition System.....	13
	Step 5: Flame Monitoring Control System.....	14
	Step 6: Main Gas Shut-Off Valve Train.....	15
	Step 7: Verify Chamber Design .....	16
	<b>Appendix</b> .....	17
	Conversion Factors .....	17

# Introduction

1

## PRODUCT DESCRIPTION

The Winnox version 1 is a nozzle-mix type, low-emissions burner designed for direct air heating, indirect air heating, and oven applications up to 1800°F (980°C).

The burner package includes a combustion air blower and an air:gas ratio regulator to fire over a wide gas turndown range at a controlled ratio.

The burner is designed for:

- low NO<sub>x</sub> and CO emissions
- efficient ratio controlled combustion
- reliable burner operation
- simple burner adjustment
- direct spark ignition
- multiple fuel capability

The wide variety of options and configurations are available due to the modular design of the burner.

**Figure 1.1 The Winnox Burner**

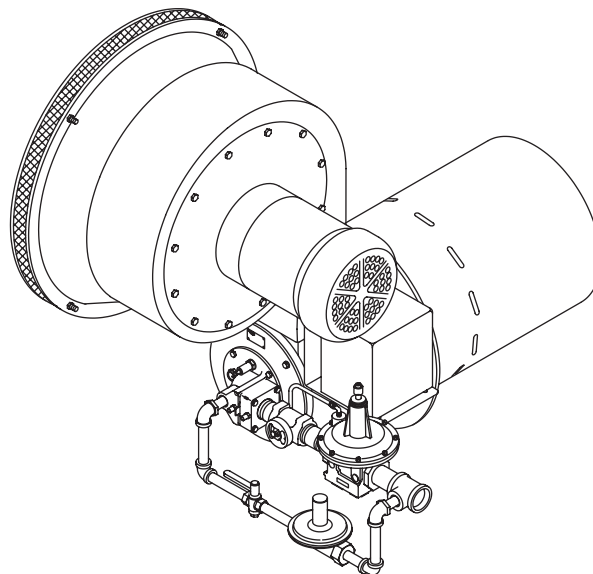

# Safety

# 2

## INTRODUCTION

This section is provided as a guide for the safe operation of Winnox burner system. All involved personnel should read this section carefully before operating this system.

## SAFETY



### **Danger:**

**The Winnox burners, described herein, are designed to mix fuel with air and burn the resulting mixture. All fuel burning devices are capable of producing fires and explosions if improperly applied, installed, adjusted, controlled, or maintained. Do not bypass any safety feature; fire or explosion could result. Never try to light a burner if it shows signs of damage or malfunction.**



### **Warning:**

**The burner might have HOT surfaces. Always wear protective clothing when approaching the burner.**



### **Note:**

*This manual provides information in the use of these burners for their specific design purpose. Do not deviate from any instructions or application limits described herein without written advice from Eclipse. Read the entire manual before attempting to start this system. If you do not understand any part of the information contained in this manual, contact Eclipse before continuing.*

## CAPABILITIES

Only qualified personnel, with good mechanical aptitude and experience with combustion equipment, should adjust, maintain, or troubleshoot any mechanical or electrical part of this system.

## OPERATOR TRAINING

The best safety precaution is an alert and trained operator. Train new operators thoroughly and have them demonstrate an adequate understanding of the equipment and its operation. A regular retraining schedule should be administered to ensure operators maintain a high degree of proficiency.

## REPLACEMENT PARTS

Order replacement parts from Eclipse only. All Eclipse approved, customer supplied valves or switches should carry UL, FM, CSA, CGA, and/or CE approval, where applicable.

# System Design

## 3

### DESIGN

#### Design Structure

The design process is divided into the following steps:

**1. Burner Option Selection Including:**

- Burner Model / Size Selection
- Fuel Type
- Air Supply
- Combustor Type
- Control Motor
- Burner Configuration
- Gas Pipe Connection
- Flame Supervision
- Air Flow Switch

**2. Blower Option Selection Including:**

- Power Supply Frequency
- Pressure and Flow
- Blower Motor Type
- Blower Inlet
- Motor Orientation

**3. Control Methodology Including:**

- Burner Control

**4. Ignition System Including:**

- Ignition Transformer
- Trial for Ignition

**5. Flame Monitoring Control System Including:**

- Flame Sensor
- Flame Monitoring Control

**6. Main Gas Shut-Off Valve Train Including:**

- Component Selection
- Valve Train Size

**7. Verify Chamber Design**

- Firing Chamber Dimensions



## Step 1: Burner Option Selection

Step 1 describes how to select burner options to suit an application. Use the Winnox Price List and Datasheets No. 111 when following this selection process.



### **Caution:**

*Consult EFE-825 Eclipse Engineering Guide, or contact Eclipse if you have special conditions or questions.*

### **Burner Model / Size Selection**

Consider the following when selecting the burner size:

- **Heat Input:** Calculate the required heat input to achieve the required heat balance. The burner air supply option selected will affect available heat output from the burner.
- **Power Supply Frequency:** Burner capacity will vary with power supply frequency (50Hz or 60 Hz power).
- **Combustion Chamber Pressure:** Consider the effects that large or varying chamber pressures have on burner performance.
- **Altitude:** The maximum burner capacity is reduced by approximately 3% each 1000 feet (300 meters) above sea level.
- **Combustion Air Supply:** Combustion air should be fresh (20.9% O<sub>2</sub>) and clean (without particles or corrosives).
- **Combustion Air Temperature:** Changes in air supply temperature can affect the burner capacity. The combustion air supply temperature should not exceed 250°F.
- **Fuel Type:** Variation in calorific value and density will affect burner performance. Nominal burner performance is based on fuel properties in Table 3.1.

**Table 3.1 Fuel Type**

Fuel	Symbol	Gross Heating Value	Specific Gravity
Natural Gas	CH <sub>4</sub> 90%+	1000 BTU/ft <sup>3</sup> (40.1 MJ/m <sup>3</sup> )	0.60
Propane	C <sub>3</sub> H <sub>8</sub>	2525 BTU/ft <sup>3</sup> (101.2 MJ/m <sup>3</sup> )	1.55
Butane	C <sub>4</sub> H <sub>10</sub>	3330 BTU/ft <sup>3</sup> (133.7 MJ/m <sup>3</sup> )	2.09
BTU/ft <sup>3</sup> @ standard conditions (MJ/m <sup>3</sup> @ normal conditions)			

If using an alternative fuel supply, contact Eclipse with an accurate breakdown of the fuel components.

### **Air Supply**

Select either a combustion air blower mounted directly to the burner body, or a pipe connection type for remote blower operation. For each selection, the burner will include an integral air butterfly valve (BV).

## Step 1: Burner Option Selection (Continued)

### Combustor Type

Select a combustor type based on the application:

Recommended Maximum Chamber Temperature °F (°C)			
Model	Standard Alloy Tube	High Temp Alloy Tube	Refractory Plug
100, 200	1300° (704°)	1550° (843°)	1800° (982°)
300, 400	1300° (704°)	1550° (843°)	1800° (982°)
500, 600	1300° (704°)	1550° (843°)	1800° (982°)
1000	1100° (593°)	1400° (760°)	Not Available

Tube and plug temperatures should be reduced 150°F when using propane or butane.



#### **Note:**

*When using a refractory plug, the customer must provide their own refractory tube set up per Eclipse dimensions.*

### Control Motor

Select a control motor. Standard control motor options include various models which Eclipse will mount to the burner. Winnox burners can be ordered with control motor bracket and mounting hardware only. Customer supplied control motors must conform to these specifications:

- rotation not to exceed 2 rpm
- minimum torque of 25 in-lb (2,8 Nm)
- 90° stroke
- continuous modulating or high/low modulating control
- reversible direction of rotation
- certain applications may require control motors with a limit switch or switches if:
  - the burner capacity is to be limited to fit an application
  - the chamber is to be fired with positive or negative pressure
  - the chamber pressure is outside the range -1" w.c. to +1" w.c. (-2,5 to 2,5 mbar)
  - there is a need to indicate a high and/or low fire air butterfly valve (BV) position

### Burner Configuration

Select configuration. See figure 3.2 on page 11 for illustrations.

### Gas Pipe Connection

Select the gas pipe connection including the pipe thread type. The piping, burner gas inlet, and fuel train components are threaded using the customer selected pipe thread option.

### Flame Supervision

Select a flame rod or an ultraviolet (UV) scanner. Both are available on all Winnox burners. If a flame rod is selected, it will be factory mounted in the burner. If a UV scanner is selected, it must be ordered separately.



#### **Warning:**

**A UV scanner can possibly detect another burner's flame if it is in the line of sight, and falsely indicate flame presence. Use a flame rod in this situation. This helps prevent accumulation of unburned fuel which, in extreme situations, could cause a fire or an explosion.**

## Step 2: Packaged Blower Option Selection

### Air Flow Switch

The air flow switch provides a signal to the monitoring system when there is not enough air pressure from the blower. If a switch is selected, it will be factory mounted.



#### **Warning:**

Eclipse supports the NFPA regulation requiring, as a minimum standard for main gas shut-off systems, the use of an air pressure switch in conjunction with other system components.

### Packaged Blower Option Selections



#### **Note:**

Standard blower options are listed in Price List 111, additional blower options are available through Eclipse. Price and leadtime may vary.

### Power Supply Frequency

Select the 50Hz or 60Hz option. The 50Hz blower motors have IEC frames and are CE marked. The 60Hz motors have NEMA frames.

### Pressure & Flow

Nominal and derated options are available.

### Blower Motor Type

Motor types include various options: voltages, single or three phase, TEFC or automotive duty enclosures.

### Blower Inlet

When selecting an inlet, consider the following:

- amount and size of particles in the air
- sound requirements
- space limitations
- cleanliness requirements of the process

### Motor Orientation

Right-hand blower motor orientation is standard. If left-hand blower motor orientation is required, contact factory.

### **Figure 3.2 Burner Configuration and Motor Orientation Choice**

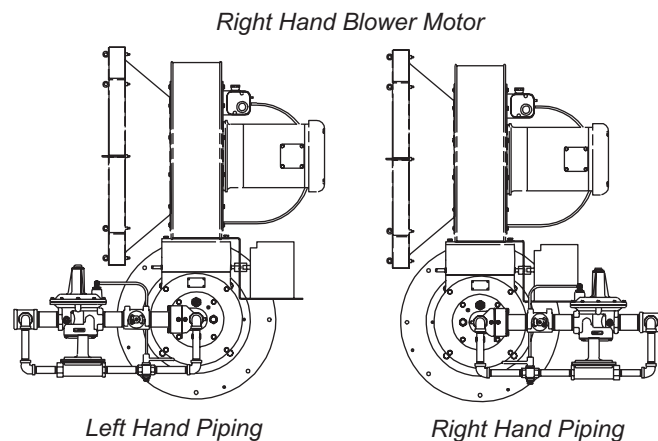

### Step 3: Control Methodology

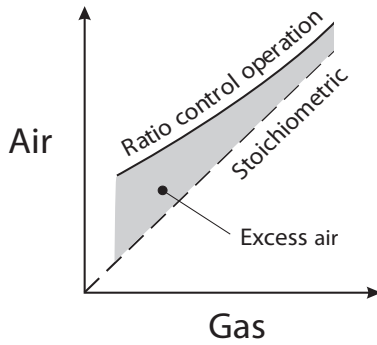

Figure 3.3 Air:Gas Flow

All standard Winnox burners are designed for:

- air:gas ratio controlled combustion
- 50% excess air at high fire
- higher excess air at low fire

### Burner Control

Winnox burners come with a ratio regulator that maintains the air:gas ratio. An integral minimum fuel bypass line is used to maintain and control a reliable low fire input flow.

Figure 3.4 Basic Burner Components

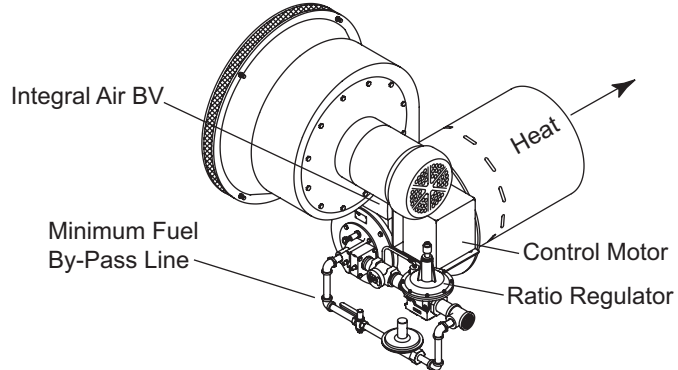

- A control signal is sent from a process temperature controller (sold separately) to the control motor. (Refer to Bulletin 818C or contact Eclipse for further information on temperature controllers.)

Figure 3.5 Basic Control Loop

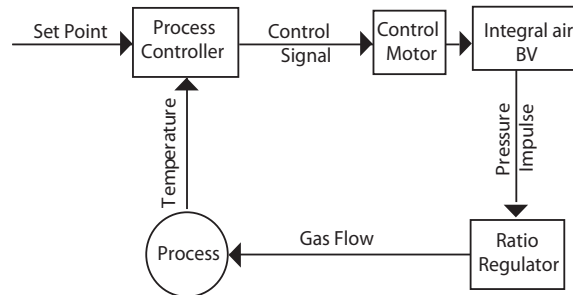

- The control motor modulates the integral air butterfly valve (BV) which controls the combustion air flow.
- Air pressure in the burner body sends an impulse down the loading line to the ratio regulator.
- The ratio regulator controls the gas flow in proportion to the air flow.



### Warning:

Do not use other control methods, such as, a fixed-air control, and do not alter the ratio regulator or burner piping without prior approval from Eclipse.

## Step 4: Ignition System

### Ignition Transformer

For the ignition system, use a transformer with:

- secondary voltage 6,000 to 8,000 VAC
- minimum secondary current 0.02 amps continuous
- full wave output

### DO NOT USE the following:

- twin outlet
- distributor type
- half wave output

### Trial for Ignition

It is required that low fire start be used.

Most local safety codes and insurance requirements limit the maximum trial for ignition time (the time it takes for a burner to ignite). These requirements vary from one location to another; check your local codes and comply to the strictest codes applicable.

The time it takes for a burner to ignite depends on the following:

- the distance between the gas shut-off valve and the burner
- the air:gas ratio
- the gas flow conditions at start-up

### Ignition Gas Piping

Winnox burners are capable of ignition with either low fire or bypass start gas.

#### Low Fire Start:

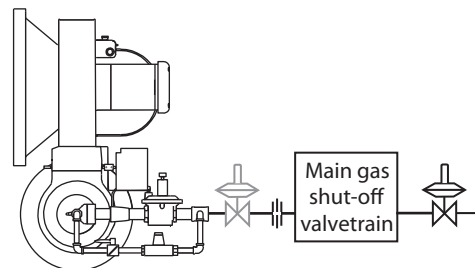

#### Pilot Start (Optional):

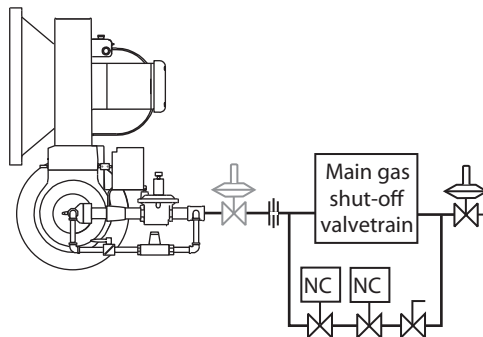

Piping for pilot start option needs to be sized to accommodate low fire gas flows as stated in datasheets.

## Step 5: Flame Monitoring Control System

Figure 3.6 Typical Sensors

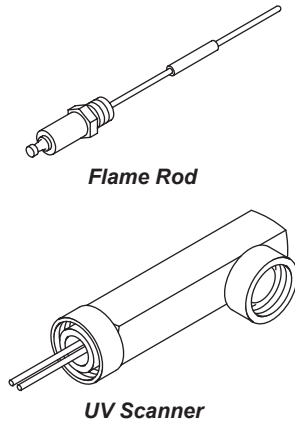

The flame monitoring control system consists of two main components:

- Flame Sensor
- Flame Monitoring Control

### Flame Sensor

Two types can be used on a Winnox Burner:

- Flame rod
- UV scanner

Flame rods are available for all Winnox burner sizes. Further information can be found in:

- Info Guide 832

A UV scanner can be used on all Winnox burner sizes. Further information can be found in:

- Info Guide 852; 90° UV scanner
- Info Guide 854; straight UV scanner
- Info Guide 856; self-check UV scanner

### Flame Monitoring Control

The flame monitoring control processes the signal from the flame rod, or UV scanner, and controls the start-up sequence and the main gas shut-off valve sequence.

Eclipse recommends the use of flame monitoring control systems which maintain a spark for the entire trail for ignition time when using UV scanners.

Some of these flame monitoring models are:

- Veri-flame; see Bulletin/Info Guide 610, 620, 630
- Bi-flame series; see Instruction Manual 826
- Multi-flame series 6000; see Instruction Manual 820

### DO NOT USE the following:

- Flame monitoring relays which interrupt the trial for ignition when the flame is detected
- Flame sensors which supply a weak signal
- Flame monitoring relays with low sensitivity

## Step 6: Main Gas Shut-Off Valve Train

### Component Selection

Eclipse can help in the design of a main gas shut-off valve train that satisfies the customer and complies with all local safety standards and codes set by the authorities within that jurisdiction. Contact Eclipse for further information.



#### **Note:**

*Eclipse supports NFPA regulations (two gas shut-off valves as a minimum standard for main gas shut-off systems).*

### Fuel Flow Measurement

Eclipse requires a fuel flow measurement device ❶. Eclipse recommendations can be found in the appropriate Winnox datasheet, series 111.

### Valve Train Size

Fuel pressure supplied to the ratio regulator inlet must be within the range specified on the Winnox datasheet, series 111. The valve train should be sized sufficiently to provide the specified pressure. A second main gas pressure regulator ❷ immediately upstream from the burner gas inlet might be necessary to maintain inlet pressure to the burner.

### Low Fire Start:

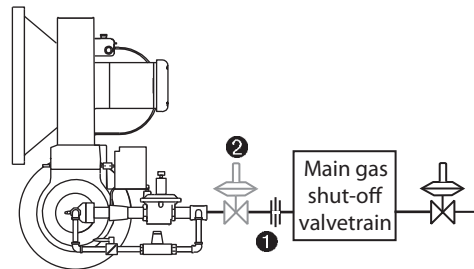

### Pilot Start (Option):

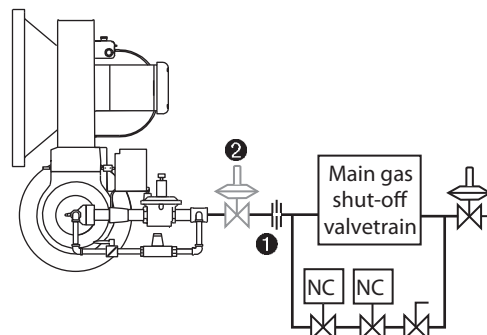

### Pilot Start (Option Using Tee Fitting):

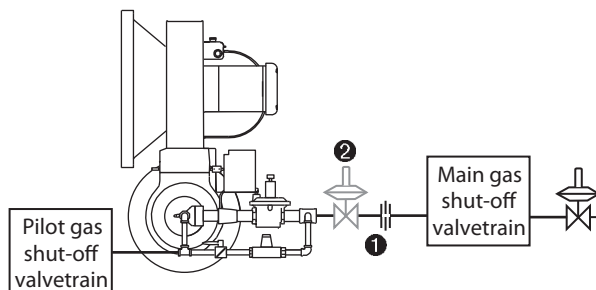

## Step 6: Main Gas Shut-Off Valve Train (Continued)



### **Note:**

*For pilot configurations using the tee fitting option to connect the pilot fuel supply ahead of the 325 series bypass regulator, back pressure to the bypass regulator must be within an acceptable limit. The bypass regulators used on all Winnox burners are designed to operate at outlet pressures up to 2 psig with inlet pressures up to 10 psig. Back load pressures (outlet pressures) of 2 psig with no inlet pressure will not affect components or the normal operation of the regulator.*



### **Warning:**

**Do not operate Winnox burners with gas inlet pressure less than the minimum listed on the Winnox datasheet. Lower gas inlet pressures may cause the ratio regulator to remain fully open at lower inputs as the burner transitions from low to high fire. This could result in the possible accumulation of unburned fuel in the burner which, in extreme situations, could cause a fire or an explosion.**

## Step 7: Verify Chamber Design

### **Firing Chamber Dimensions**

The Winnox is a low emissions burner that might require a larger firing chamber than a standard burner.

Chamber dimensions are a function of chamber temperature, process air volume and burner input. Contact your Eclipse representative to review your chamber design.





# Appendix

## CONVERSION FACTORS Metric to English

From	To	Multiply By
cubic meter (m <sup>3</sup> )	cubic foot (ft <sup>3</sup> )	35.31
cubic meter/hr (m <sup>3</sup> /h)	cubic foot/hr (cfh)	35.31
degrees Celsius (°C)	degrees Fahrenheit (°F)	(°C x 1.8) + 32
kilogram (kg)	pound (lb)	2.205
kilowatt (kW)	BTU/hr	3414
meter (m)	foot (ft)	3.28
millibar (mbar)	inches water column ("w.c.)	0.401
millibar (mbar)	pounds/sq in (psi)	14.5 x 10 <sup>-3</sup>
millimeter (mm)	inch (in)	3.94 x 10 <sup>-2</sup>
MJ/m <sup>3</sup> (normal)	BTU/ft <sup>3</sup> (standard)	2.491 x 10 <sup>-2</sup>

## Metric to Metric

From	To	Multiply By
kiloPascals (kPa)	millibar (mbar)	10
meter (m)	millimeter (mm)	1000
millibar (mbar)	kiloPascals (kPa)	0.1
millimeter (mm)	meter (m)	0.001

## English to Metric

From	To	Multiply By
BTU/hr	kilowatt (kW)	0.293 x 10 <sup>-3</sup>
cubic foot (ft <sup>3</sup> )	cubic meter (m <sup>3</sup> )	2.832 x 10 <sup>-2</sup>
degrees Fahrenheit (°F)	degrees Celsius (°C)	(°F - 32) ÷ 1.8
foot (ft)	meter (m)	0.3048
inch (in)	millimeter (mm)	25.4
inches water column ("w.c.)	millibar (mbar)	2.49
pound (lb)	kilogram (kg)	0.454
pounds/sq in (psi)	millibar (mbar)	68.95
BTU/ft <sup>3</sup> (standard)	MJ/m <sup>3</sup> (normal)	40.14



**Offered By:**

Power Equipment Company  
2011 Williamsburg Road  
Richmond, Virginia 23231  
Phone (804) 236-3800  
Fax (804) 236-3882

---

[www.peconet.com](http://www.peconet.com)